



10 Reasons You'll Love Kisag Blenders

1. High Performance Motor
2. Selectable 2 Speed Gear Box
3. Ergonomic Handle Design
4. Heat Resistant Handle (220°C)
5. Long Cable
6. Sealed Shaft
7. Stainless Steel Construction
8. Can Be Operated With One Hand
9. CE Certified
10. Two Year Commercial Warranty





High quality, multipurpose mixer for professional use. Especially suitable for use in catering establishments, large kitchens, hotels, hospitals, bakeries etc.

Features

Ergonomic Design

- Uniquely designed handle allows for prolonged use with comfort
- Easy to operate in any position
- Heat resistant handle that hooks onto the side of cooking vessel
- Due to the handle design the blender won't roll off a work surface.
- Long cable

Performance

- High performance motor designed for continuous use
- Selectable speed, two speed motor
- One piece mono block motor and shaft
- Direct power, no lag

Hygiene

- Shaft and blade made from specially selected stainless steel
- Sealed shaft, prevents liquid from entering drive shaft
- Easy to clean under running tap

Reassurance

- Quality Swiss engineering
- CE Certified
- Commercial warranty



High quality, multipurpose mixer for professional use. Especially suitable for use in smaller catering establishments.



Kisag Power Stick Blender 20

Item Number: FPMX0274

Usage: 8 minutes permanent use
Size: Shaft 200mm Power: 250 Watt
Capacity: up to 20 Litres

DESIGN DETAIL

Shaft, foot & knife all in stainless steel, special multipurpose knife for blending, mixing, chopping whipping cream etc....
High quality, strong motor with selectable speeds 15,000 & 20,000 RPM.



High quality, multipurpose mixer for professional use. Especially suitable for use in catering establishments, large kitchens, hotels etc.



Kisag Power Stick Blender 40

Item Number: **FPMX0275**

Usage: 15 minutes permanent use

Size: Shaft 400mm

Power: 550 Watt

Capacity: up to 150 Litres

DESIGN DETAIL

Housing cast aluminum, anodised, Shaft, foot & knife all in stainless steel, special multipurpose knife for blending, mixing, chopping whipping cream etc....2 speeds (14'000 & 17'000 RPM) and permanent speed selectable.

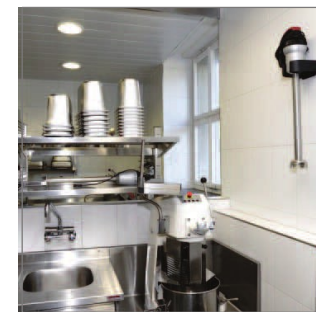

High quality, multipurpose mixer for professional use. Especially suitable for use in catering establishments, large kitchens, hotels etc.

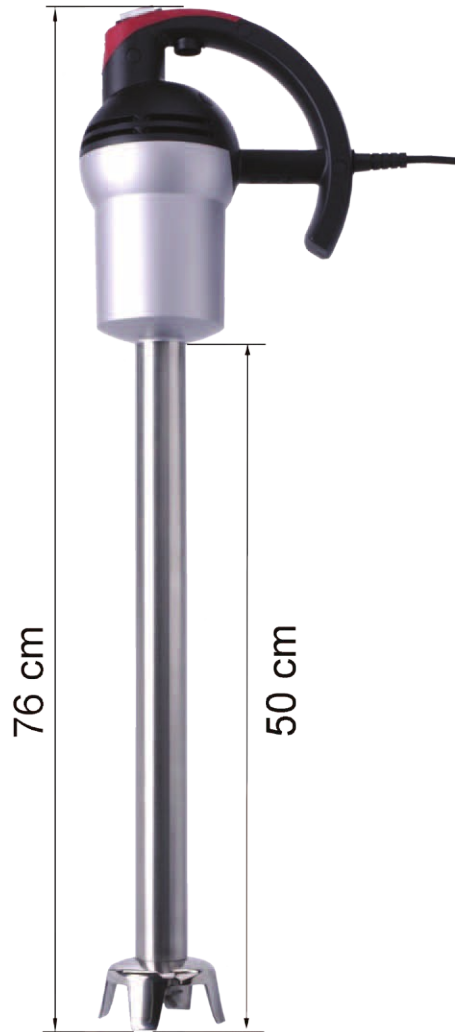

Kisag Power Stick Blender 50

Item Number: FPMX0276

Usage: 15 minutes permanent use

Size: Shaft 500mm

Power: 550 Watt

Capacity: Up to 200 litres



DESIGN DETAIL

Housing cast aluminum, anodized, Shaft, foot & knife all in stainless steel, special multipurpose knife for blending, mixing, chopping whipping cream etc....2 speeds (14'000 & 17'000 RPM) and permanent speed

